

Chain / Stem / Surface Mount

- Chain (provided by others)
- Surface Mount Standard Bracket (Standard, provided)
- External Stud Mounting Bracket (Option **BRKT1**)
- 1/2" Stem Pendant Mount Bracket (Option **BRKT2**)

Standard Surface Mount Bracket

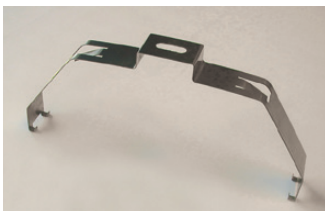

* Chain can be installed (provided by others)

Pendant Mount Bracket (BRKT2)

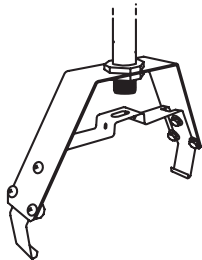

* 1/2" pipe provided by others



External Stud Mounting Bracket (BRKT1)

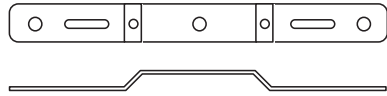

* 2pcs locknut provided.

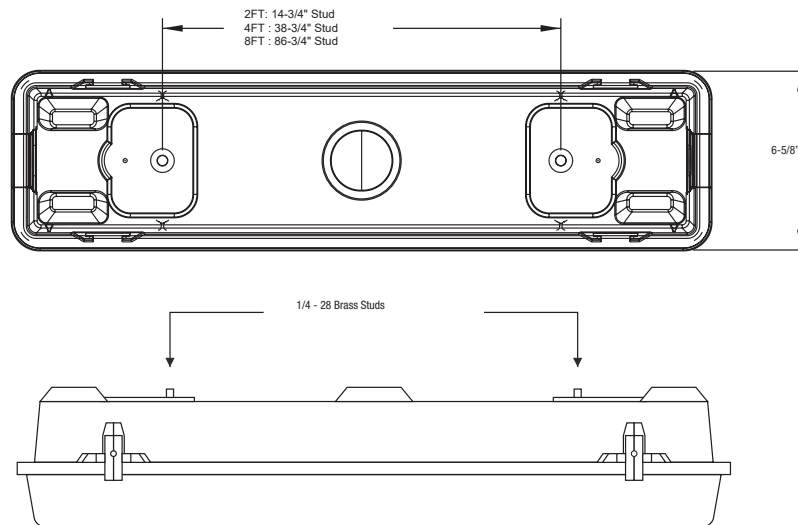
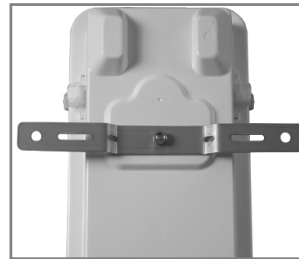

* Any damage caused from improper installation will void warranty and not be accepted for RGA (Return Goods Authorization). Improper installation includes but not limited to field-drilled hole(s), improper latch closure and any damage caused during installation.

Contractor is responsible for adequately reinforcing ceilings to support luminaire weight. Utopia Lighting accepts no responsibility for inadequately reinforced ceilings. The information contained in this drawing is the sole property of Utopia Lighting.

Any reproduction in part or whole without the written permission of Utopia Lighting is prohibited and warranty is voided.

