

LPT-12

Project Name:	
Type:	



APPLICATION

Precisely designed smooth PC lens provides ideal lights curve and perfect uniformity. Professional designed specific lights angle for excellent uniformity of light output. It is designed to work in building perimeter areas and public spaces completing a wide variety of architectural styles.

FEATURES:

- Corrosion resistant heavy duty cast aluminum construction.
- Passes 3G vibration testing.
- Superior powder coat finish to withstand the weather.
- Wiring compartment on the top for easy access and installation.
- Type VS distribution.
- EPA: 2.7ft²

MOUNTING:

- 2-3/8" standard, 3" optional.

LENS:

- Injection molded, UV polycarbonate lens.

LED:

- Color Temperature: 3000/4000/5000K
- CRI: >70
- Lumen Efficiency: ≥107 lm/W
- L70>55,000hrs

ELECTRICAL:

- Input voltage: 120-277V, 50/60Hz
- 1-10V dimmable.
- Operating temperature: -40°F (-40°C) ~ 104°F (40°C)
- Power Factor: >0.90, THD<20%
- Class P, Class 2

LISTING:

- UL / cUL wet location listed.
- DLC premium listed. ¹
- 5 years warranty.

CONFIGURATIONS

	Model	Input Watts	Lumen Output (30/40/50K)	Lumen Efficiency (30/40/50K)	B.U.G. Rating
LPT-12	53LED	53W	7007 lm	132 lm/W	B2-U2-G1
	82LED	82W	10201 lm	124 lm/W	B3-U3-G1
	136LED	136W	14555 lm	107 lm/W	B3-U3-G1
	3SH	100/125/150W	12800/16000/19220 lm	128 lm/W	B3-U3-G1
	3SL	45/60/80W	5355/7140/9567 lm	119 lm/W	B3-U3-G1

HD401 FACTORY SETTING (TABLE 1)

Detection Area	100%
Hold-time	5 sec
Daylight sensor	Disable
Stand-by period (tri-level control)	0 sec
Stand-by dimming level	10%

* See a separate attachment to find more setting options.

ORDERING INFORMATION

EXAMPLE: LPT-12-82LED-40K-UNV-BZ

MODEL	LED	COLOR TEMP.	VOLTAGE	FINISH	DISTRIBUTION	
LPT-12	53LED 82LED 136LED	53W LED 82W LED 136W LED	-30K 3000K -40K 4000K -50K 5000K	UNV 120-277V (Std.)	BZ *WH Dark Bronze (RAL#7022) (Std.) White (RAL#9010) <small>* Non-standard finish with extra charge.</small>	(Blank) Type VS (Std.)
	3SH 3SL	Selectable 100/125/150W LED ³ Selectable 45/60/80W LED ³	-3T Selectable 30/40/50K			

MOUNTING		OPTIONS	
(Blank) P3 WM	2-3/8" Pole 3" Pole Wall Mount	TLPC3 HD401 SP10	3-Pin Receptacle and Twist Lock Photocell Installed 120V-277V Microwave motion sensor with daylight, 0-10V, adjustable via DIP switch ² 10Kv surge protector

NOTES:

1. DesignLights Consortium® (DLC) qualified product. Not all versions of this product may be DLC qualified. Please check the DLC Qualified Products List at www.designlights.org/QPL to confirm which versions are qualified.
2. See Table1 and attachment to find more information.
3. Built in photocell as standard.

LPT-12

DIMENSIONS

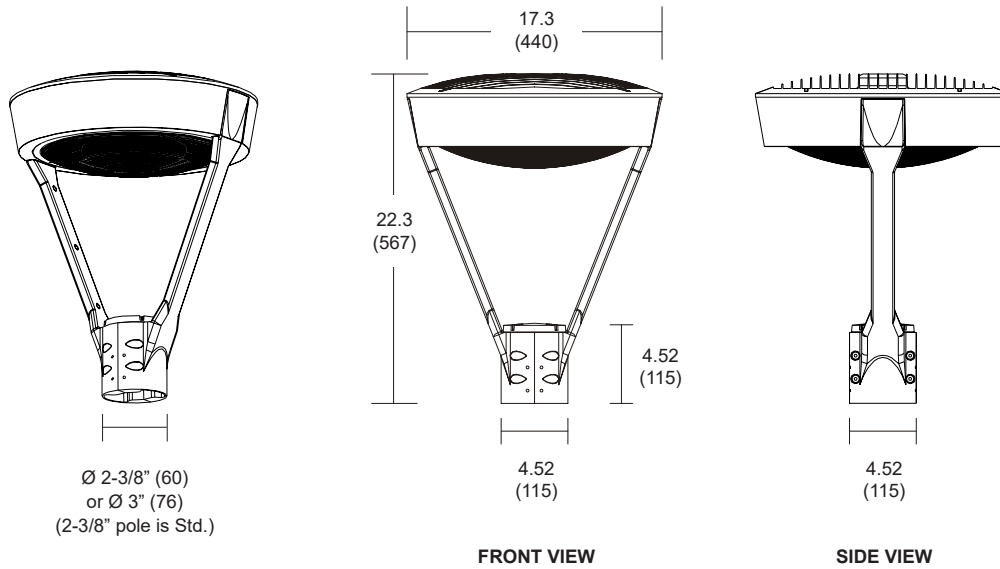

* All dimensions are in inches (millimeters).

