

RGB+W WIRING DIAGRAM

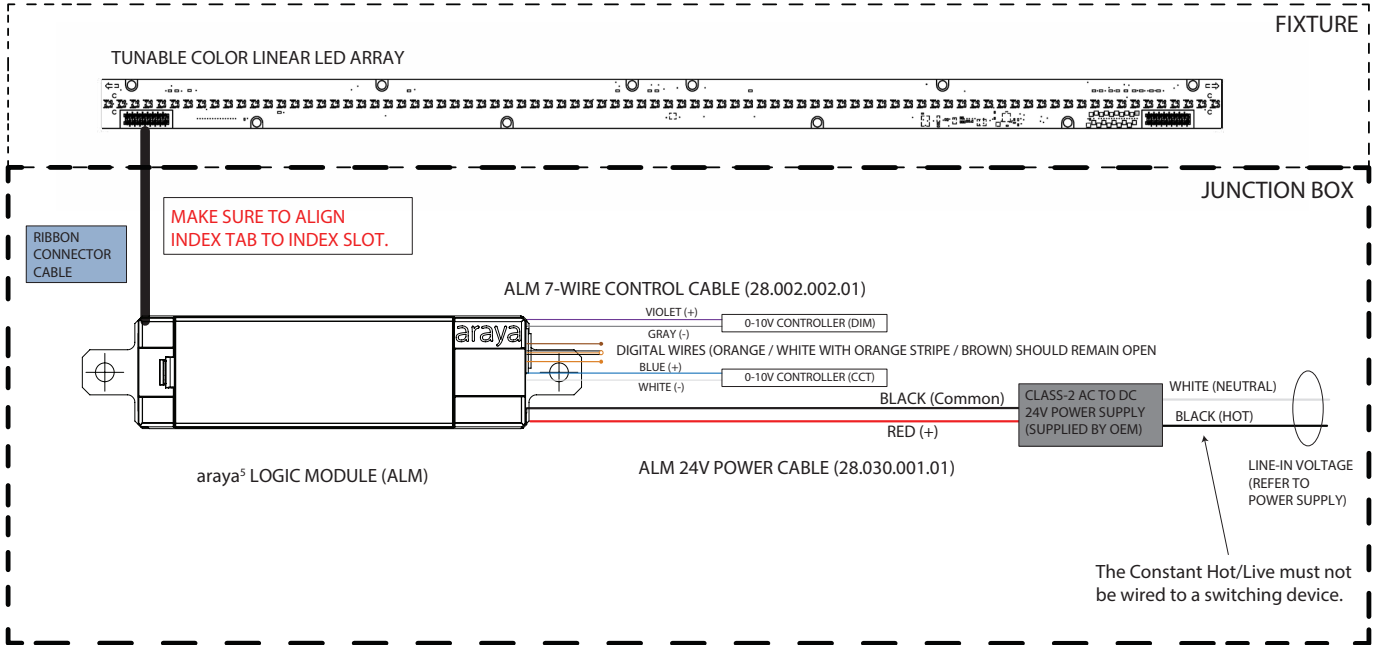

0-10V CONTROL



TUNABLE COLOR 2.0 iOS APP

(MAX. OF 8 MODULES CAN BE COMMISSIONED AT A TIME)

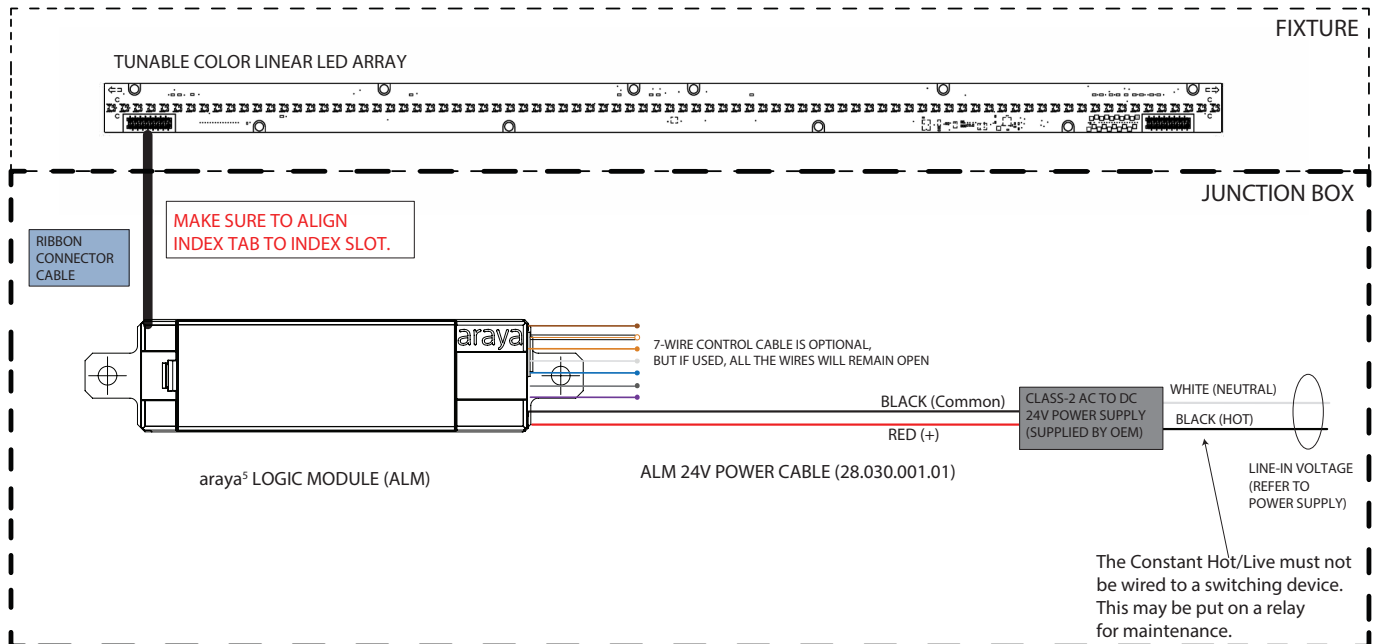

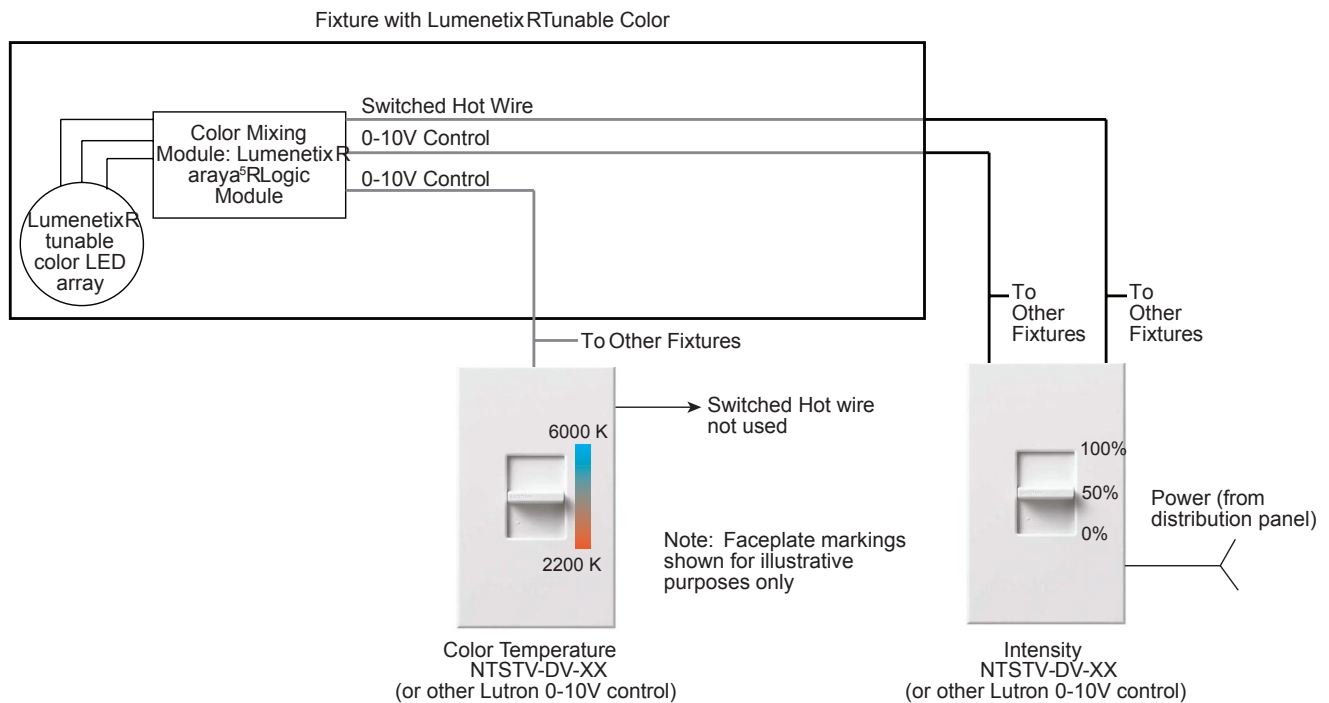

Figure 13: Lutron Nova T* slide dimmers providing independent control of intensity and color temperature of a Lumenetix Rfixture with a tunable color LED array fixture inside.

Notes:

Lumenetix modules operate between 1-10V. All dimmers that have minimum and maximum trim pots should be set at a minimum of 1 volt and a maximum of 10 volts, measuring the voltage at the end of the line.

0-10V Dimmers (recommended list)*

- Crestron
- ETC
- Fresco
- Legrand
- Leviton
- Lutron
- Nexlight
- N-Light
- Pass & Seymour
- Vantage
- Wattstopper

NOTE: BLUETOOTH OPERATION IS FOR COMMISSIONING THE MODULES ONLY, NOT FOR CONTROLLING THEM.

DMX512-A CONTROL

DMX512-A Recommended Field Wiring

- Liberty 24-2P-485 (Non-Plenum), 24 AWG, 2 pair dual 120 ohm, 11.2 pf/ft low capacitance (Wago, XLR and PHX connectors)
- Liberty 24-2P-P485 (Plenum), 24 AWG, 2 pair dual 120 ohm, 11.2 pf/ft low capacitance (XLR and PHX connectors)
- Belden #9842 (Non-Plenum), 24 AWG, 2 pair dual shielded 120 ohm, 12.8 pf/ft low capacitance (XLR and PHX connectors)
- Belden #89842 (Plenum), 24 AWG, 2 pair dual shielded 120 ohm, 12.8 pf/ft low capacitance (XLR and PHX connectors)

Please refer to wire manufacturer’s lighting catalog for and/equals as required by code.

Category Wire or Equal

The Entertainment Services and Technology Association (ESTA) does not define a maximum run length for DMX over Cat5 since many factors will affect the maximum run length, such as number of devices, number of splices in the cable, the strength of the DMX transmitter(s), if Remote Device Management (RDM) is being used, and sources of interference. ESTA does state (again, in ANSI E1.21-2): “A properly selected and installed DMX512 cable should provide acceptable signal strength for runs of 300m (1000ft). Please note that the technical requirements, such as run-length and topology for other networking technologies, such as Ethernet, should be considered if using the installed cable for another networking technology in the future is anticipated.”

Cat5 or equivalent is not preferred as a portable cable since it is not as rugged as other DMX cables. Male RJ45 connectors are especially prone to breakage over repeated re-connections.

LUMENETIX RECOMMENDATION:

- CAT 5E -150 FEET
- CRESTRON
- DM-CBL-8G-NP
- DM-CBL-8G-P

- CAT 7- 330 FEET
- CRESTRON
- DM-CBL-ULTRA-NP
- DM-CBL-ULTRA-P

DMX512-A Recommended Field Connectors (or Equal)

- WAGO 221
- PHOENIX CONTACT
- XLR NEUTRIK
- CRESTRON
- RJ45 DM -8G-CONN
- RJ45 IDC DM-CONN

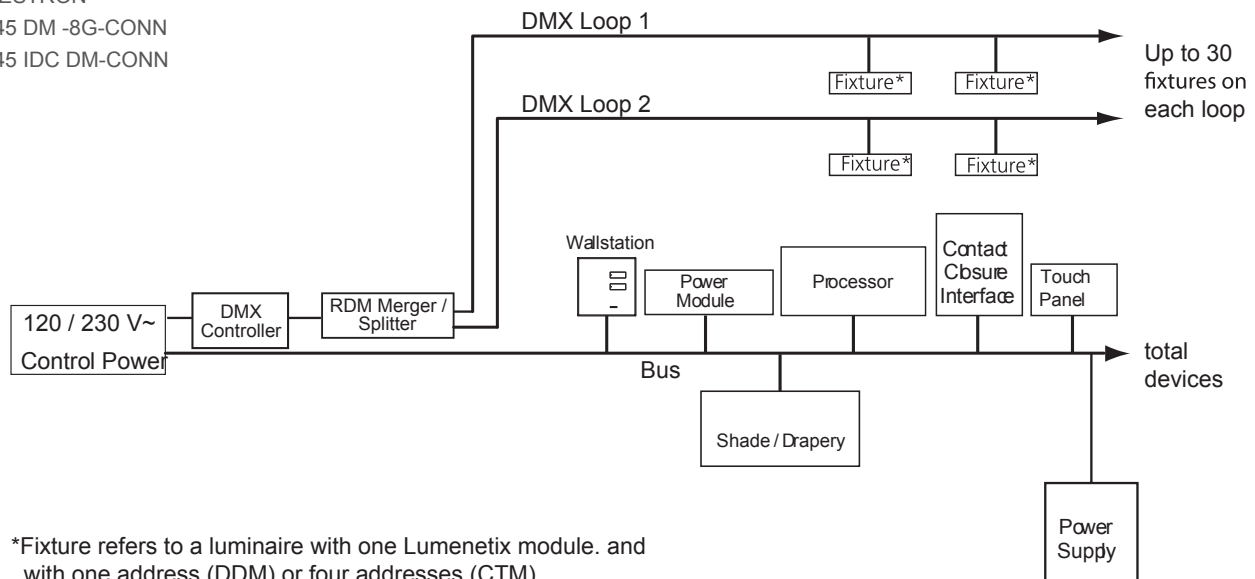

*Fixture refers to a luminaire with one Lumenetix module. and with one address (DDM) or four addresses (CTM).

DMX SLOTS SET BY RDM OR
BY TUNABLE COLOR 2.0 iOS APP



(MAX. OF 8 MODULES CAN BE
COMMISSIONED AT A TIME)

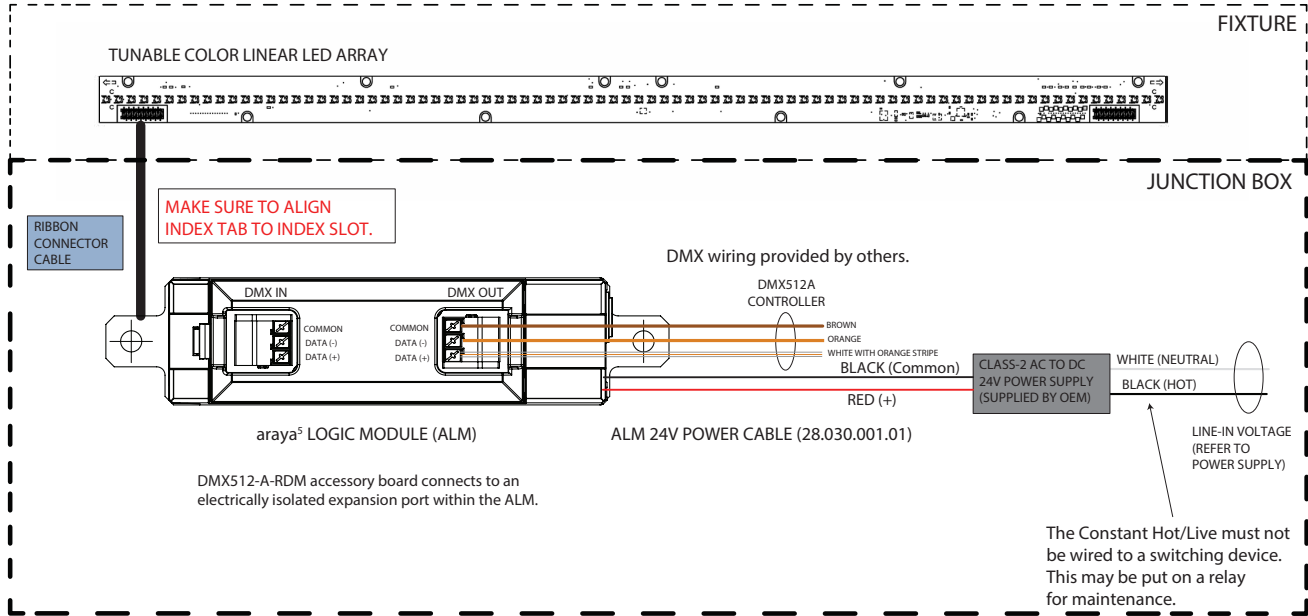

Default DMX512-A Slot Allocation:

Slot	Function
1	Dim Level
2	CCT
3	Saturation Level
4	Hue

DMX512-A Wiring Connections

Signal	Description	Pin Colors (4-Pair Cable)	Pin Colors (2-Pair Cable)	3-pin XLR connector	5-Pin XLR connector	5-Pin PHX connector
Signal Common		White/Brown and Brown	White/Blue and Blue	1	1	1
Data (-)	Primary Data Link	Orange	Orange	2	2	2
Data (+)	Primary Data Link	White/Orange	White/Orange	3	3	3
Data2 (-), or not used	Optional Secondary Data Link				4	4
Data2 (+), or not used	Optional Secondary Data Link				5	5

XLR Connectors (5-Pin)

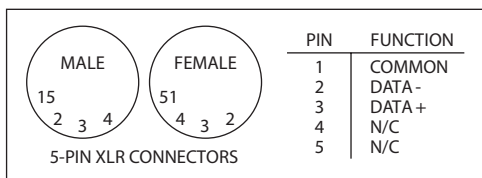

RJ-45 Connector Pin-Out (T568B)

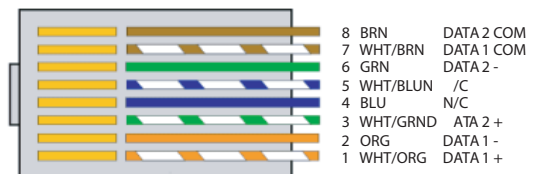

Parameter	Range	Remarks
Receiver type	Isolated	
ESD Protection	±15KV (air), ±8KV (conducted)	Per IEC 61000-4-2
Termination	Recommended	The DMX512 bus termination rules apply
Directionality	Receive only	
Frequency stability	±20ppm	
Load per port	1/256	1/8 of Nominal RS-485
Isolation	3KVrms	

DMX512-A Drain Wire Connections

Drain wire connections are required as follows.

Shielding

To add another level of protection from electromagnetic noise, a grounded shield is added over the twisted pair wires. When this is enclosed in a protective jacket, to avoid ground loops and electromagnetic contamination of the ground system, all control ground wiring, including cable shields and drain wires, should be treated like sensitive current-carrying conductors. All control ground wires should be insulated (not bare) and the same wiring practices should be observed with ground wires as with other sensitive signals. Care must also be taken when designing control wiring to ensure that each shield is connected to only a single ground point. You should establish this point at a central location, like a control panel or cabinet, and avoid all connection to grounds in the field. A control ground is sometimes referred to as an isolated ground (an oxymoron) for this reason, but the term single-point ground is more accurate.

Method-1

A typical two-pair shielded cable can be prepared for termination to the terminals with the drain wire cut off. This is usually done at the field end of the cable where no shield grounding is desired. You will then use insulating tape or heat-shrink tubing to protect the cable from contamination and to prevent accidental grounding of the shield or drain wire. An accidental ground at this point would almost certainly create an undesirable ground loop.

Method-2

A typical two-pair shielded cable can be prepared for termination to the terminals with the drain wire cut off. The drain wire, which is an uninsulated conductor, is sleeved with a insulating tubing to prevent accidental grounding. The crimp-on lug is valuable in this instance to retain the tubing. Insulating tape or heat-shrink tubing is again used to protect the cable from contamination and to prevent accidental grounding, since any accidental connection between the drain wire and a chassis, frame, or enclosure would almost certainly create a ground loop.

DMX512-A Control Systems (recommended list)

Choreo
Cognito
Crestron Greenlight System
Entec
ETC Mosaic
ETC Paradigm
Fresco
Lutron HomeWorks QS
Lutron Quantum
Nicolaudie
Pathway Connectivity
Pharos
Traxon Ecue
Vantage Controls

NOTE: BLUETOOTH OPERATION IS FOR COMMISSIONING THE MODULES ONLY, NOT FOR CONTROLLING THEM.

LUTRON ECOSYSTEM CONTROL

Lutron EcoSystem Controller Example

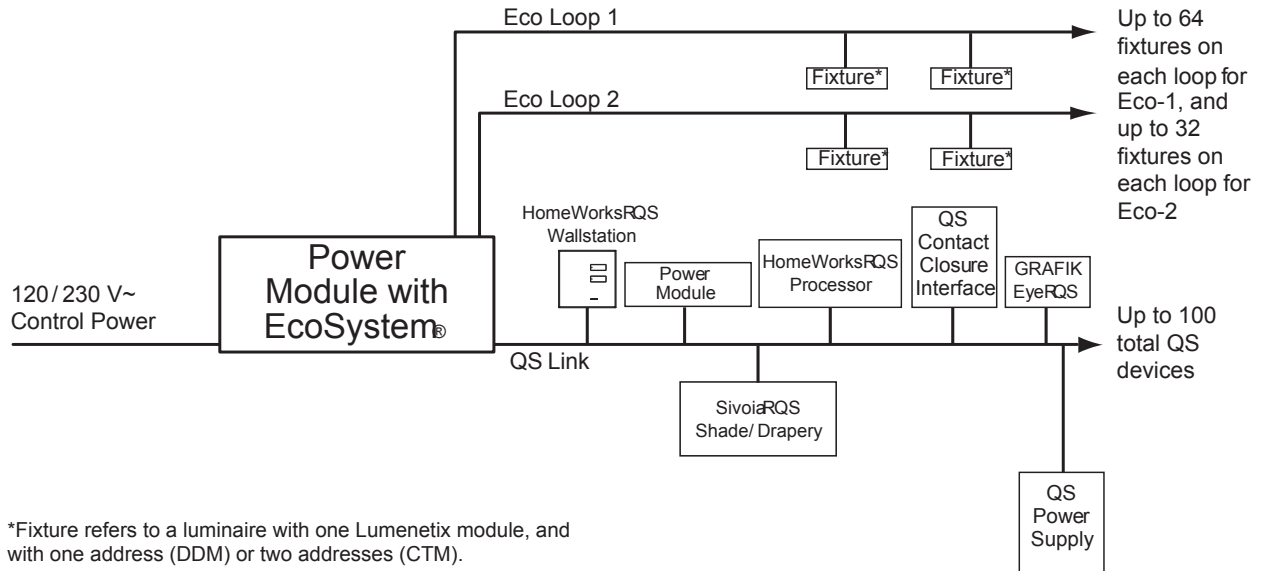

*Fixture refers to a luminaire with one Lumenetix module, and with one address (DDM) or two addresses (CTM).

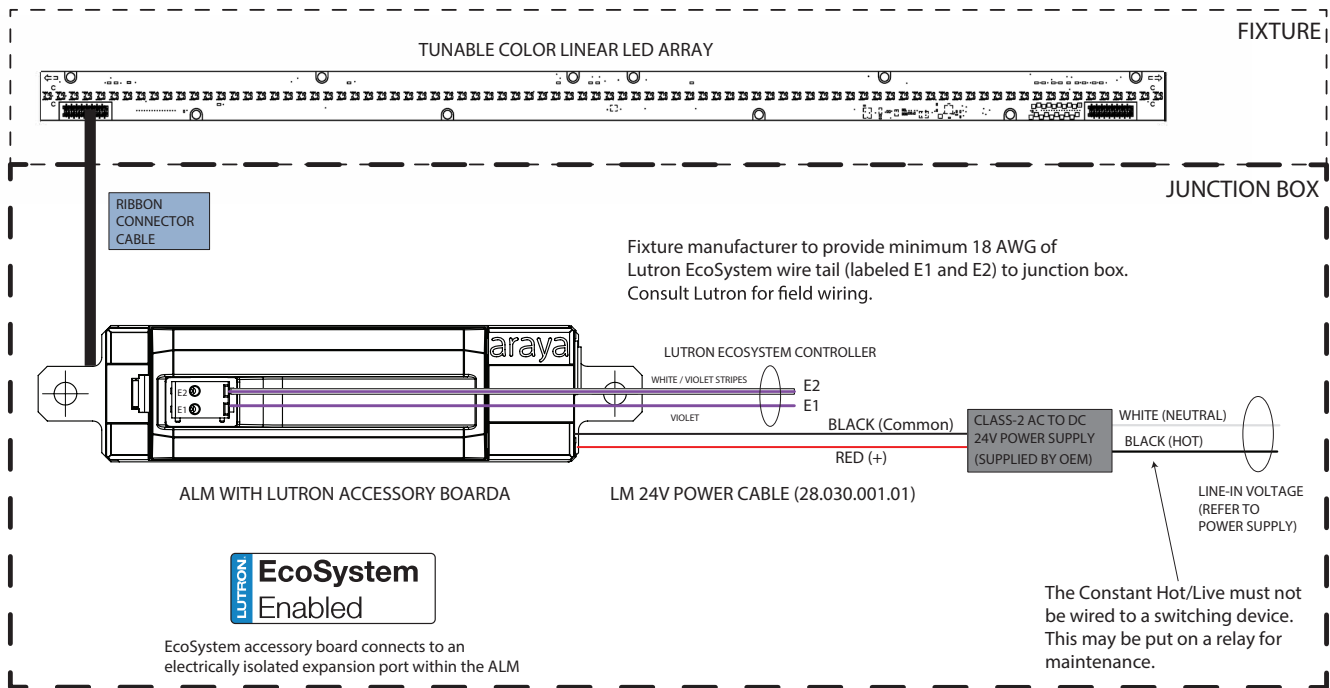

Notes:

1. 24V power (red/black) is Class-2 rated.
2. EcoSystem Channel 1 is always Intensity control. EcoSystem Channel 2 is always CCT control.
3. In the EcoSystem programming mode, EcoSystem Channel 1 controls the intensity from 100%-1%. EcoSystem Channel 2 controls the CCT range from 1650 - 8000K.

EcoSystem Control Systems (recommended list)*

Quantum System

HomeWorks QS

Grafik Eye QS Control Unit with EcoSystem

EnergiSavr Node with EcoSystem

Power Module with EcoSystem

PowPak RMJ-ECO-32-DV-B



Wattstopper®

DLM Araya and Blanco Module Daughter Board

Carte fille de module DLM Araya et Blanco

Placa secundaria DLM del módulo Araya y Blanco

Installation Instructions • Instructions d'Installation • Instrucciones de Instalación

No: 25191 – 07/17 rev. 2

Catalog Number • Numéro de Catalogue • Número de Catálogo: LMLM-101

Country of Origin: Made in China • Pays d'origine: Fabriqué en Chine • País de origen: Hecho en China

SPECIFICATIONS

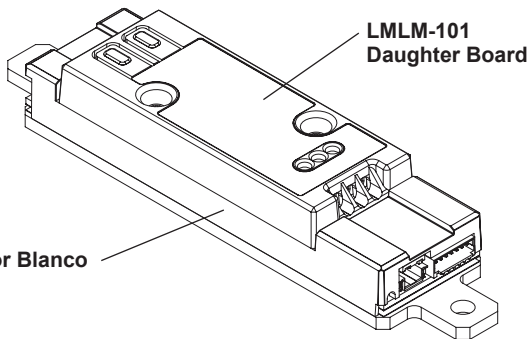

DLM Voltage.....	24VDC
DLM Current Consumption.....	2mA
DLM Power Supply.....	Wattstopper room controllers/power booster
Voltage	24-48VDC
Current Consumption	* See Note below
Power	Provided by Araya or Blanco module
Connection to DLM Local Network.....	1 or 2 RJ-45 ports per fixture
Class 2 dimming control signal.....	from LMLM-101 to Logic module
Environment:	
Operating Temperature	32° to 131°F (0° to 55°C)
Storage Temperature	23° to 176°F (-5° to 80°C)
Relative Humidity	10 to 95% (non condensing)

* The LMLM-101 counts as a device on the DLM Local Network. The LMLM-101 draws power from the Araya or Blanco Logic Module (8mA max, 24-48VDC)

This unit is pre-set for Plug n' Go™ operation, adjustment is optional.

For full operational details, adjustment and more features of the product, see the DLM System Installation Guide provided with Wattstopper room controllers, and also available at www.legrand.us/wattstopper.

Installation shall be in accordance with all applicable regulations, local and NEC codes. Wire connections shall be rated suitable for the wire size (lead and building wiring) employed.

Installation shall be in accordance with all applicable regulations, local and NEC codes. Fixture assembly, UL Listing compliance, and Class 1/ Class 2 wiring separation best practices are the responsibility of the fixture OEM and/or installing contractor

CONNECTIVITY

The LMLM-101 communicates with all other DLM devices connected to the DLM Local Network. Connections shown are for example only. The low voltage LMRJ cables can connect to any DLM device with an open RJ45 receptacle.

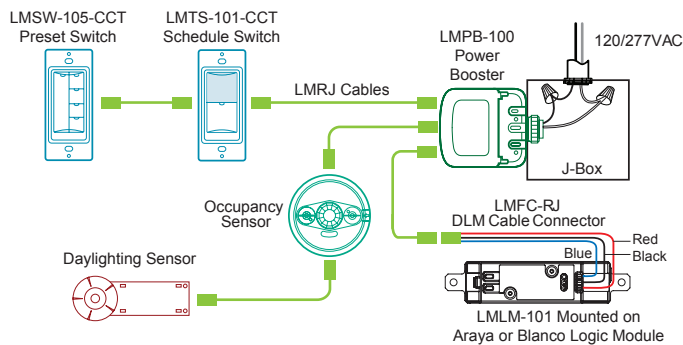

NOTE: Each DLM local network must include a DLM room controller, relay panel, or power booster to supply low voltage power to the LMLM-101.

CAUTION
 TO CONNECT AC COMPUTERS TO THE DLM LOCAL NETWORK USE THE LMCI-100. NEVER CONNECT THE DLM LOCAL NETWORK TO AN ETHERNET PORT—IT MAY DAMAGE COMPUTERS AND OTHER CONNECTED EQUIPMENT.

PLUG N' GO OPERATION (PNG)

For a detailed explanation of PnG operation and sequencing with multiple units, see the LMZC-301 installation instructions.

Load Control Arbitration

To take full advantage of automatic PnG configuration, review these simple rules about load control arbitration.

After the room controllers are connected to the DLM Local Network and powered up, they automatically negotiate to determine which controller becomes the Master, as well as the load numbers for each relay on the DLM Local Network. The **Master** is the controller powering the bus with the highest serial number. If an zone controller is connected, it will be the master. But if room controllers are used without the LMZC-301, then the one with the highest serial number will be the master.

In a DLM local network with only LMLM-101 fixture controllers (and the LMZC-301), the LMLM-101 with the highest serial number controls Load 1. The next highest serial number controls Load 2, and so forth.

If a plug load controller is used instead of a room controller, the fixture controller loads are numbered first, and then the plug load controller.

UNIT ADJUSTMENT - PUSH N' LEARN (PNL)

Load Selection Procedure

A configuration button (Config) allows access to Wattstopper's patented Push n' Learn™ technology to change binding relationships between sensors, switches and loads.

NOTE: Unlike the LMRC and LMPL products, the installation of the LMLM-101 inside of a fixture means that though this method is supported, it is primarily suited to assembly line verification. Field verification should be done using LMCS software whenever possible to avoid fixture disassembly.

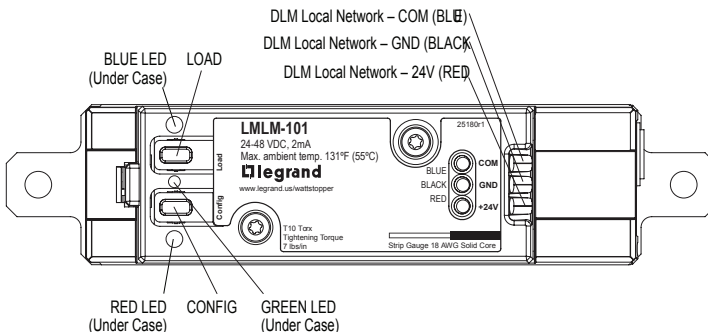

Blue LED ON when load is ON.

Green LED indicates communication established between LMLM-101 and Araya or Blanco module

RED LED ON when in Push n' Learn mode.

Load button:

**Press & release for ON/OFF.
Press & hold to Dim.**

Step 1 Enter Push n' Learn

1. **Press and hold the Config button (on any DLM device) for 3 seconds.**
2. The red LED on the LMLM-101 begins to blink. When you release the button, the red LEDs on other communicating devices connected to the DLM Local Network begin to blink. They continue to blink until you exit PnL mode.
3. All loads in the room turn OFF immediately after entering PnL, then one load will turn ON. This is Load #1, which is bound to switch button #1 and occupancy sensors as part of the Plug n' Go factory default setting. **All switch buttons and sensors that are bound to this load have their blue LED solid ON.**

Step 2 Load selection

1. Press and release the Config button to step through the loads connected to the DLM Local Network. As each load turns ON note the devices (switch buttons and sensors) that are showing a bright solid blue LED. These devices are currently bound to the load that is ON. The blue LED on the room controller or plug load controller connected to the load is also lit
 - To **unbind** a switch or dimmer button from a load, press the switch button while its blue LED is ON bright. The blue LED goes dim to indicate the button no longer controls the load that is currently ON.
 - To **unbind** an occupancy sensor, press the up (▲) or down (▼) adjustment button while its blue LED is ON. The blue LED turns OFF to indicate the sensor no longer controls the load that is currently ON.
 - Pressing the switch button or sensor up (▲) or down (▼) again while the load is ON **rebinds** the load to the button or sensor and the blue LED illuminates brightly.

Step 3 Exit Push n' Learn

Press and hold the Config button until the red LED turns OFF, approximately 3 seconds.

TROUBLESHOOTING

LEDs turn ON and OFF but load doesn't switch	<ol style="list-style-type: none"> 1. Make sure the DLM local network is not in PnL. 2. Check connections to fixture controller.
Lamps do not dim, or lamps drop out at low dim levels	<ol style="list-style-type: none"> 1. Check wiring per ballast manufacturer's instructions.

DALI TYPE8 CONTROL

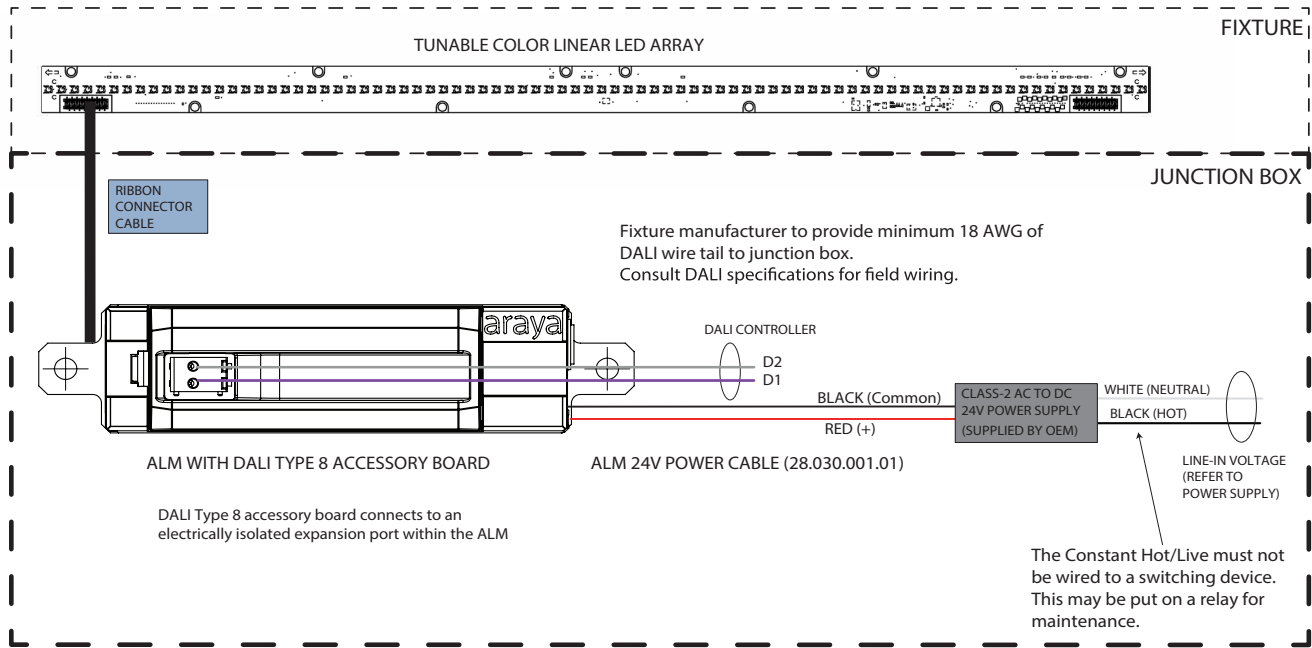

Notes:

1. 24V power (red/black) is Class-2 rated.
2. One DALI address per linear array / ALM kit.

DALI Technical Specifications:

Numbers of units: max. 64
 Numbers of addresses: 64
 Signal level: +/- 16V
 Cable length: max. 300m, and less than 2V voltage drop
 Cable type: any 2 wire unshielded cable
 Cable topology: any (line, star, tree, ring)
 Refresh rate: max 40 messages / second +/- 1200 baud Safety
 DALI is not SELV; cable must be treated like mains wiring

Maximum DALI-compliant Bus Wire Length:

1.5 mm² (300 m)
 0.75 mm² (150 m)
 0.50 mm² (100 m)

The following are National Electric Code (NEC 70) requirements.

DALI Class 1 and Class 2 Wiring Overview:

DALI dimming ballasts and drivers are connected together by a 2-wire low voltage bus that is suitable for Class 1 or Class 2 wiring installations. This application note explains how both Class 1 and 2 wiring are made and how they both meet National Electric Code (NEC) regulations.

DALI Dimming Ballast and Driver Wired Class 2:

For more information on Class 2 wiring and additional Class 2 wiring requirements see National Electric Code Article 725. With regards to factory installed wiring, as per UL1598 section 6.17.1: Factory-installed power limited wiring and branch circuit wiring that come in random contact within the luminaire shall have insulation rated for the maximum voltage that exists in any of the circuits.

If wiring with the properly rated insulation is used, then no spacing or separation is required regardless of the circuit conductor voltage although shielding may be required.

Class 2 wiring of the DALI dimming ballast and driver follows the NEC Requirement 725.136(D) (references to Class 3 are eliminated).

Class 2 circuit conductors in compartments, enclosures, device boxes, outlet boxes, or similar fittings shall be permitted to be installed with electric light, power, Class 1 circuits where they are introduced solely to connect the equipment connected to Class 2 circuits and where (1) or (2) applies:

1. The electric light, power, Class 1 circuit conductors are routed to maintain a minimum of 6 mm (.25 in) separation from the conductors and cables of Class 2.
2. The circuit conductors operate at 150 volts or less to ground and also comply with one of the following:
 - A. The Class 2 circuits are installed using Type CL3, CL3R, or CL3P or permitted substitute cables provided these Class 3 cable conductors extending beyond the jacket are separated by a minimum of 6 mm (0.25 in) or by a nonconductive sleeve or nonconductive barrier from all other conductors.
 - B. The Class 2 circuit conductors are installed as a Class 1 circuit.

The DALI dimming ballast and driver have a minimum spacing of 0.25 inches between line voltage and the bus terminals (purple and grey wires) for Class 2 installations.

DALI Bus Wired Class 1:

Class 1 wiring methods follow the NEC Requirement 725.48.

Class 1 circuits shall be permitted to be installed with other circuits as specified in 725.48 (A) and (B):

- A. Class 1 circuits shall be permitted to occupy the same cable, cable tray, enclosure, or raceway without regard to whether the individual circuits are alternating or direct current, provided all conductors are insulated for the maximum voltage of any conductors in the cable, cable tray, enclosure or raceway.
- B. Class 1 circuits shall be permitted to be installed with power supply conductors as specified:
 1. Class 1 and power supply circuits shall be permitted to occupy the same cable, enclosure, or raceway only when functionally associated.

Since the DALI dimming ballast and driver meets Class 2 installation requirements, it can also be installed in a Class 1 configuration when Class 2 markings are not present. The NEC allows the reclassification of Class 2 circuits per Article 725.130 Exception No.2:

Class 2 and circuits shall be permitted to be reclassified and installed as Class 1 circuits if the Class 2 markings are eliminated and the entire circuit is installed using the wiring methods and materials in accordance with Part II, Class 1 circuits.

Note: For more information regarding Class 2 wiring and additional requirements see the National Electrical Code Article 725.

Reference Information:

Code quotation, guidance, and wiring guides above are listed for reference only. Always follow local and national wiring requirements. NEC 2008 was used as a reference in this Application Note. More recent releases of the National Electrical Code should always be consulted. The National Electrical Code (NEC) is a registered trademark of the National Fire Protection Association, Quincy, MA.